

efi sales Ltd.

Equipment for the Foodservice Industry

value + quality + service

Single Chamber Food Warmer

SA-FWNP



SA-FWNP

Features

Features:

- 1 full size chamber
- Stainless steel for easy cleaning
- 95°C maximum cooking temperature
- 21 litre capacity
- Adjustable thermostat

Warranty

- 1 year parts and labour



SA-FWNP

Specifications

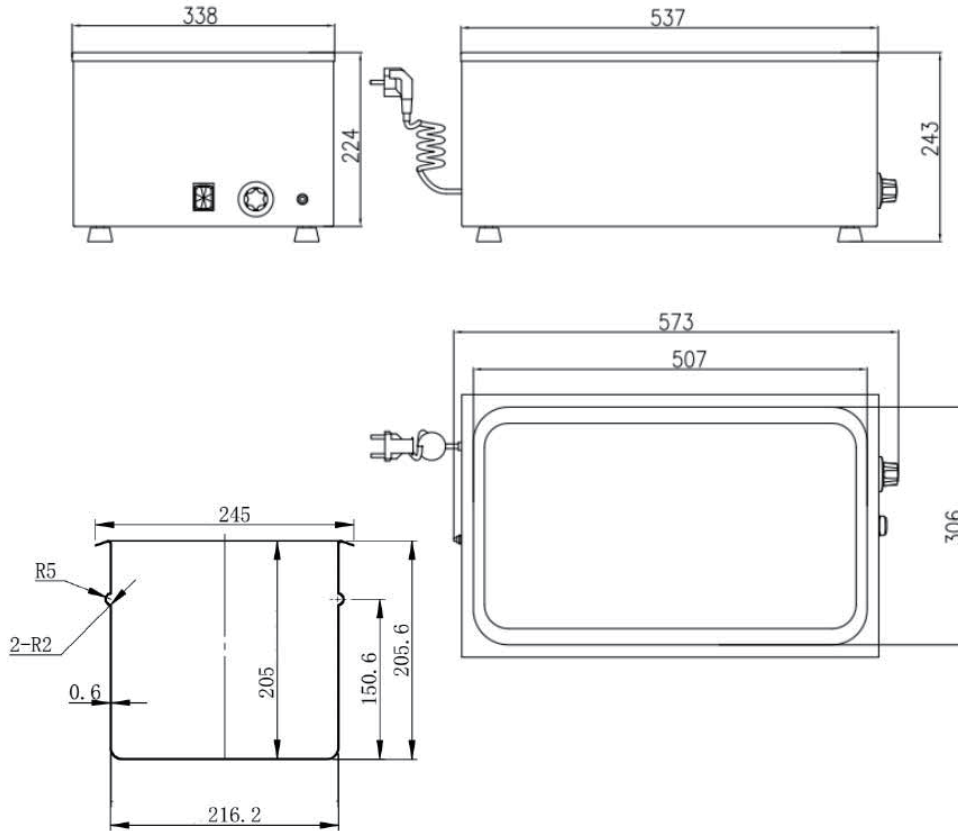

Model	Dimension (mm) (inch)			Capacity	Voltage	Power	Net Weight (KG) (LBS)
	W	D	H				
SA-FWNP	338	573	243	21 litre Chamber	120/60	1200 watts	6.85
	13.3	22.6	9.5				15.0

Equipped with one NEMA 5-15P plug 

Shipping Information

Crate Dimensions (mm) (inch)			Net Weight (KG) (LBS)	Gross Weight (KG) (LBS)
W	D	H		
392	638	298	6.85	8.2
15.4	25.1	11.7	15.0	18.1

Specifications subject to change without notice.