

efi sales Ltd.

Equipment for the Foodservice Industry
value + quality + service

Cube Ice Machine

Model No:
IM-160



IM-160

Features

Features:

- Corrosion resistant exterior
- Door allows easy access to ice in the bin
- Durable core micro-computer control system for quick and easy operation
- A special built-in follow water type evaporator, increases the transparency and hardness of the ice
- Special injection tank, simple and clean, nice heat preservation performance, effectively keeps ice more hard
- Unique ice type gives a refreshing, crisp and clean tasting full cube sized ice

- Easy to adjust the thickness of the ice depending on your requirements

Warranty:

- One year parts and labour. *For full warranty details visit <https://www.efifoodequip.com/warranty-info.php>*



IM-160

Specifications

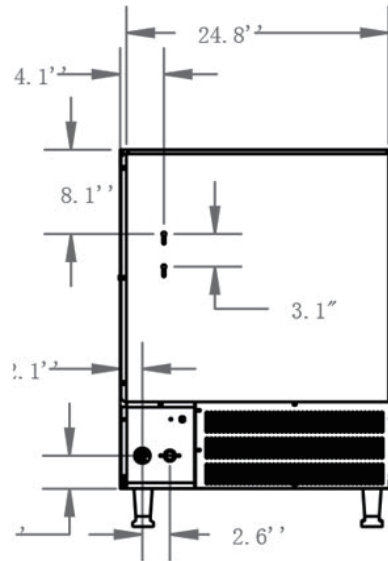
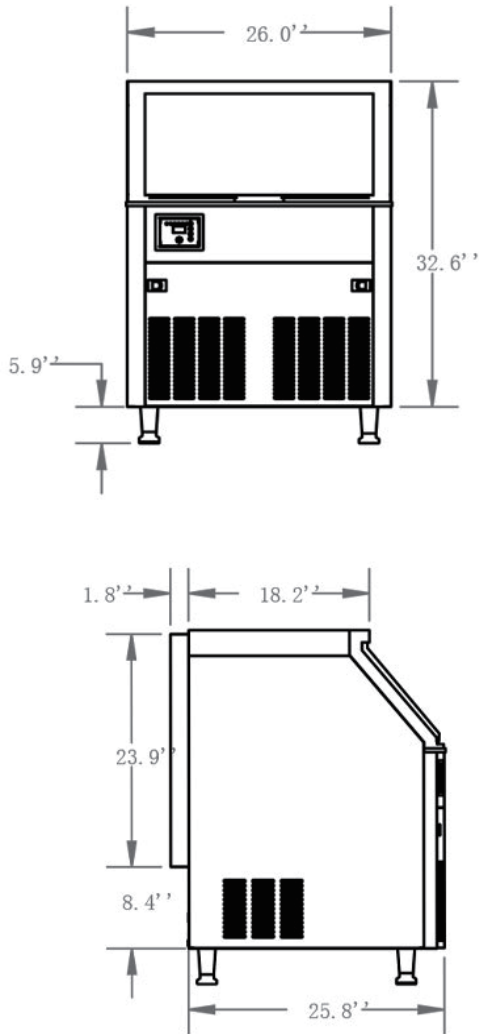

Model	Refrigerant	Dimension (mm) (inch)			Condenser Unit	Voltage (V/Hz)	Power (W)	Bin Capacity (kg) (lb)	Output LB/24hr (kg) (lb)	Net Weight (kg) (lb)
		W	D	H						
IM-160	R290	660	701	978	Air	115/60	451	36	73	65
		26	27.6	38.5						

Specifications subject to change without notice.