

**efi** sales Ltd.

Equipment for the Foodservice Industry  
value + quality + service

## Hot Show Cases

HCGS-3526



### HCGS-3526

### Features

#### Features:

- Brilliant internal LED illumination on top
- Adjustable temperature controller
- Temperature display
- Adjustable chrome plated shelves
- Front and back sliding doors

#### Warranty:

- One year limited warranty parts and labour.  
*For full warranty details visit <https://www.efifoodequip.com/warranty-info.php>*



**HCGS-3526**

**Specifications**

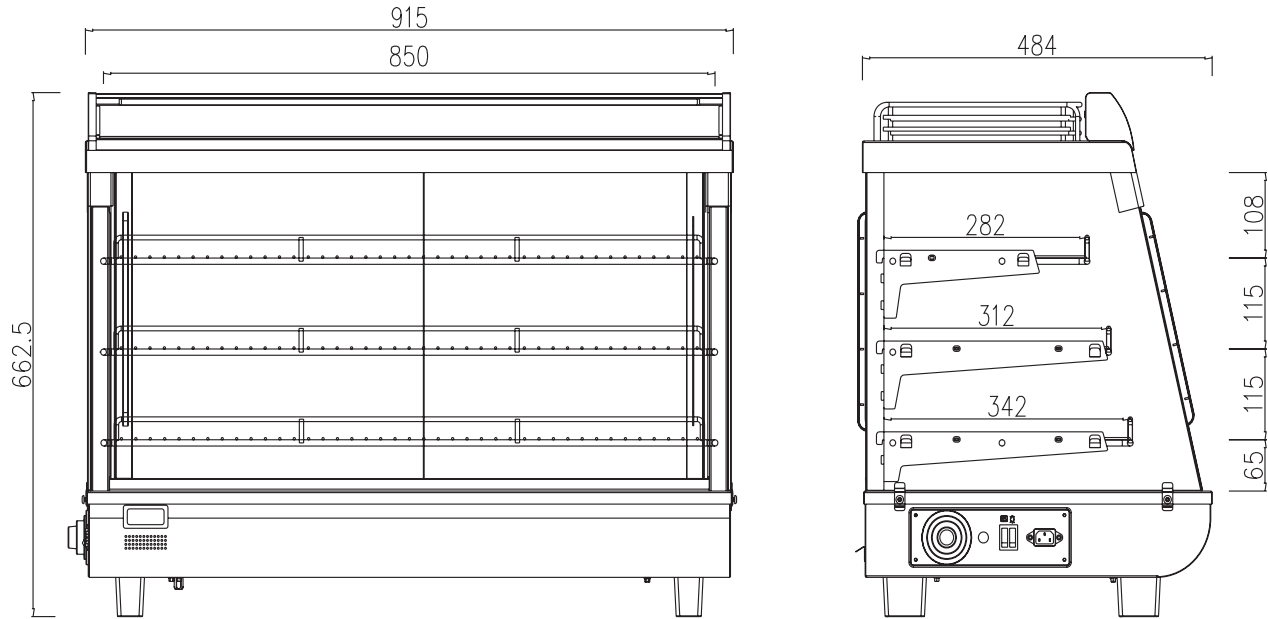

Model	Dimension			Voltage	Amps	Capacity (L) (Cu Ft.)	Net Weight (KG) (LBS)	Temperature Range
	L	D	H					
HCGS-3526	915	484	662.5	115/60	10	136	41.5	30-90°C
	36.0	19.1	26.1					

Equipped with one NEMA 5-15P plug 

*Specifications subject to change without notice.*