



Equipment for the Foodservice Industry

value + quality + service

Bottom Mount Reach-in Freezer

F2-39VC



F2-39VC

Features

Features:

- Bottom-mounted cooling unit is easy to remove and clean
- Environmentally friendly R290 refrigerant
- Exterior & interior stainless steel construction
- Dixell digital temperature control system
- Heavy duty Embraco compressor
- Self-closing and stay open door
- Auto evaporation of defrosting water
- Recessed door handles
- Safe lock for safe and secure use
- Removable gasket that is easy to clean and replace
- Adjustable/removable plastic coated wire shelves
- Shelves can be set-up to hold standard full size hotel pans
- Casters for easy movement

Warranty:

- Two year parts and labour; Five years on compressor.
For full warranty details visit <https://www.efifoodequip.com/warranty-info.php>



F2-39VC

Specifications

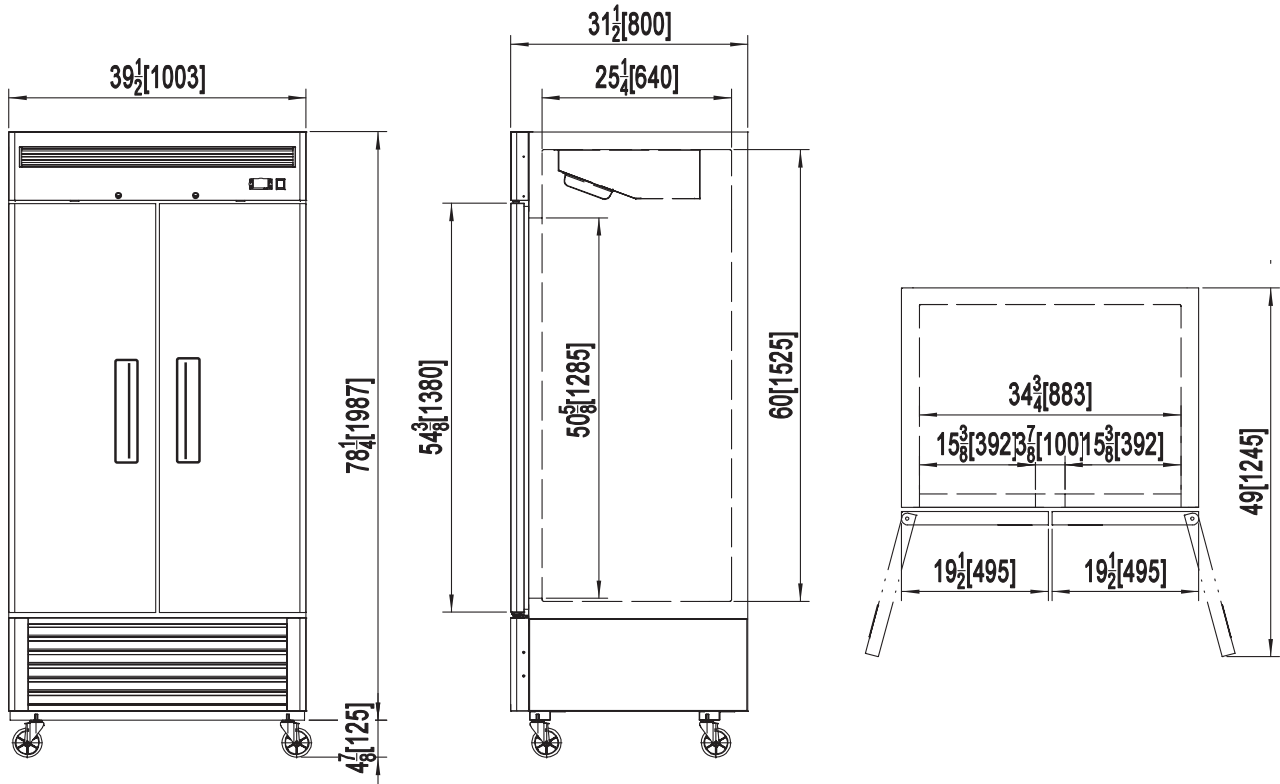

| Model | Refrigerant | Doors | Shelves | Dimension (mm) (inch) | | | HP | Voltage | Amps | Capacity (L) (Cu Ft.) | Net Weight (KG) (LBS) | Temperature Range |
|---------|-------------|-------|---------|-----------------------------|------|------|-----|---------|------|-----------------------------|--------------------------------|----------------------|
| | | | | L | D | H | | | | | | |
| F2-39VC | R290 | 2 | 6 | 1003 | 800 | 2135 | 3/4 | 115/60 | 8.6 | 855 | 150 | -8 ~ -1°F |
| | | | | 39.5 | 31.5 | 84.1 | | | | | | |

Equipped with one NEMA 5-15P plug 

Shipping Information

| Crate Dimensions (mm) (inch) | | | Net Weight (KG) (LBS) | Gross Weight (KG) (LBS) |
|------------------------------------|------|------|-----------------------------|-------------------------------|
| L | D | H | | |
| 1054 | 861 | 2154 | 170 | 188 |
| 41.5 | 33.9 | 84.8 | 375 | 415 |

Specifications subject to change without notice.