

efi sales Ltd.

Equipment for the Foodservice Industry
value + quality + service

X-LINE 72" Worktop Refrigeration with Backsplash

Model No:
CWDR3-72VCX



CWDR3-72VCX Features

Features:

- Exterior & interior stainless steel construction
- Environmentally friendly R290 refrigerant
- Heavy duty Embraco compressor
- Self-closing and stay open door
- Efficient refrigeration system holds 33°F to 45°F (0.5°C to 8°C)
- Recessed door handle
- Removable gasket that is easy to clean and replace
- Casters for easy movement
- Pre-installed shelves

Warranty:

- Two year parts and labour; Five years on compressor. For full warranty details visit <https://www.efifoodequip.com/warranty-info.php>



CWDR3-72VCX Specifications

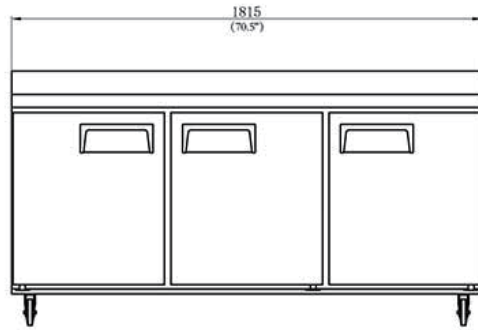

ELEVATION

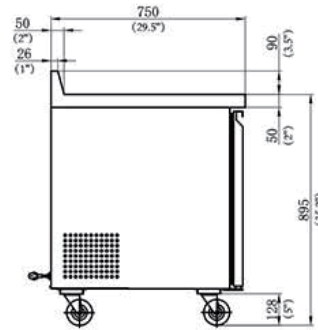

SECTION VIEW

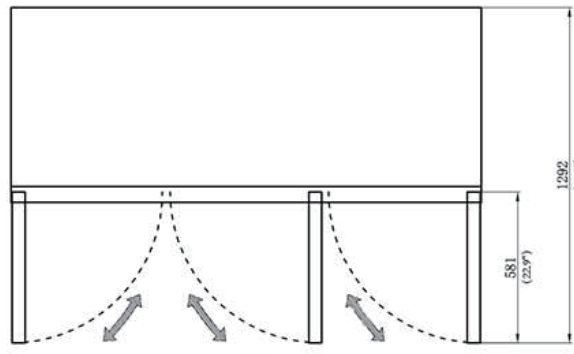

PLAN

Model	Refrigerant	Doors	Shelves	Dimension (mm) (inch)			HP	Voltage	Amps	Capacity (L) (Cu Ft.)	Net Weight (KG) (LBS)	Temperature Range
				W	D	H						
CWDR3-72VCX	R290	3	3	1815	750	984	1/5	115/60	2.8	598	135	0.5 ~ 8°C
				71.5	29.5	38.7						

Equipped with one NEMA 5-15P plug 

Shipping Information

Crate Dimensions (mm) (inch)			Net Weight (KG) (LBS)	Gross Weight (KG) (LBS)
W	D	H		
1885	820	1070	135	173
74.2	32.3	42.1	297.6	381.4

Specifications subject to change without notice.